



RoboMicro

DS18B20 Connection

RoboMicro: Connecting To DS18B20 Sensor

Description

This document will help you to connect a DS18B20 Digital Temperature Sensor to RoboMicro.

The idea of using RoboMicro to control/command the DS18B20 is that all the “hard-work” of driving the DS18B20 is done for you. RoboMicro can control up to four DS18B20 sensors.

To allow RoboMicro to control DS18B20 sensors, the unique ID of each sensor needs to be stored in RoboMicro, in one of the four available slots. Once RoboMicro knows the ID of the DS18B20, it can control the sensor and report back “real-world” temperature values.

When RoboMicro has been correctly configured, the user may disconnect and reconnect the DS18B20 Sensors without disabling the “1-Wire” driver first. The “1-Wire” driver will adjust to missing/re-connected DS18B20 sensor automatically.

Connection Overview

The DS18B20 Digital Temperature Sensor uses a 1-Wire bus to communicate with the outside world. RoboMicro has a “1-Wire” bus built in, as well as a firmware driver to allow RoboMicro to control equipment connected to the “1-Wire” bus.

The firmware driver can control up to 4 DS18B20 Sensors connected to the RoboMicro “Sensor Net”. The “Sensor-Net” is a convenient way of describing the way RoboMicro controls the DS18B20 sensors that are connected. (For more information on “1-Wire” bus and addressing, please refer to the “1-Wire” Bus standard).

A small PCB is available which allows a DS18B20 sensor to be mounted and connected into the RoboMicro “Sensor-Net”.

RoboMicro “1-Wire” Bus

RoboMicro will always be the “1-Wire” Bus Master, and comes with the required “pull-up” resistor fitted to the DQ (Digital Input 4) Line. There is no need to apply any additional bus termination, unless the length of the bus becomes excessive.

The RoboMicro “1-Wire” bus can be routed round a Robot chassis without any problems. It is best to keep the “1-Wire” bus away from High-Power/High-Current wires (motor wires, etc) – due to noise and other inference causing errors on the bus.

Sensor PCB Connections (With DD18B20 Fitted)

This drawing shows the connection details when using the small RoboSensor PCB with a DS18B20 fitted.

- **V (Sensor Supply)** is connected to **V** of the **Digital Input Connector** on **RoboMicro**
- **G (Signal Ground)** is connected to **G** of the **Digital Input Connector** on **RoboMicro**
- **1** is connected to **Digital Input 4** of the **Digital Input Connector** on **RoboMicro**

The RoboSensor PCB allows multiple PCB's to be "Daisy-Chained" together.

(View from Top)

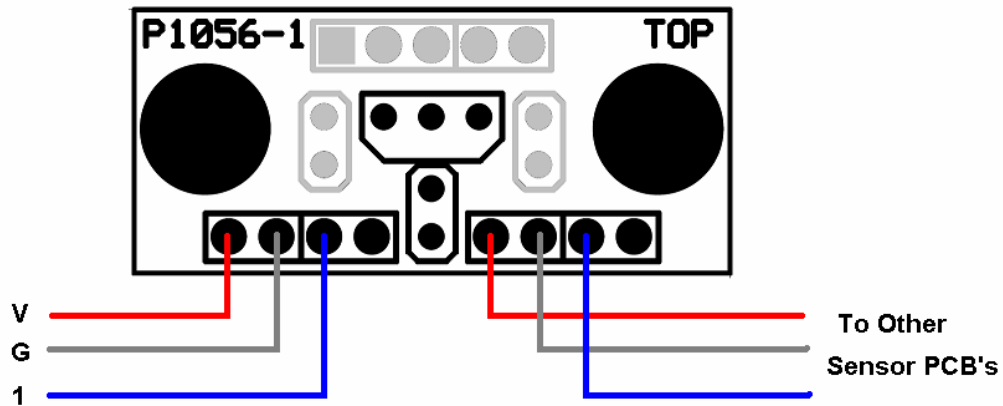

DS18B20 Connections Direct To RoboMicro

This drawing shows the connection details when connecting four DS18B20 Digital Temperature Sensors to RoboMicro.

- The GND pins of the DS18B20 are connected to the G (ground) pin of RoboMicro
- The Vdd pins of the DS18B20 are connected to the V (+5V) pin of RoboMicro
- The DQ pins of the DS18B20 are connected to the 4 (Digital Input 4) pin of RoboMicro

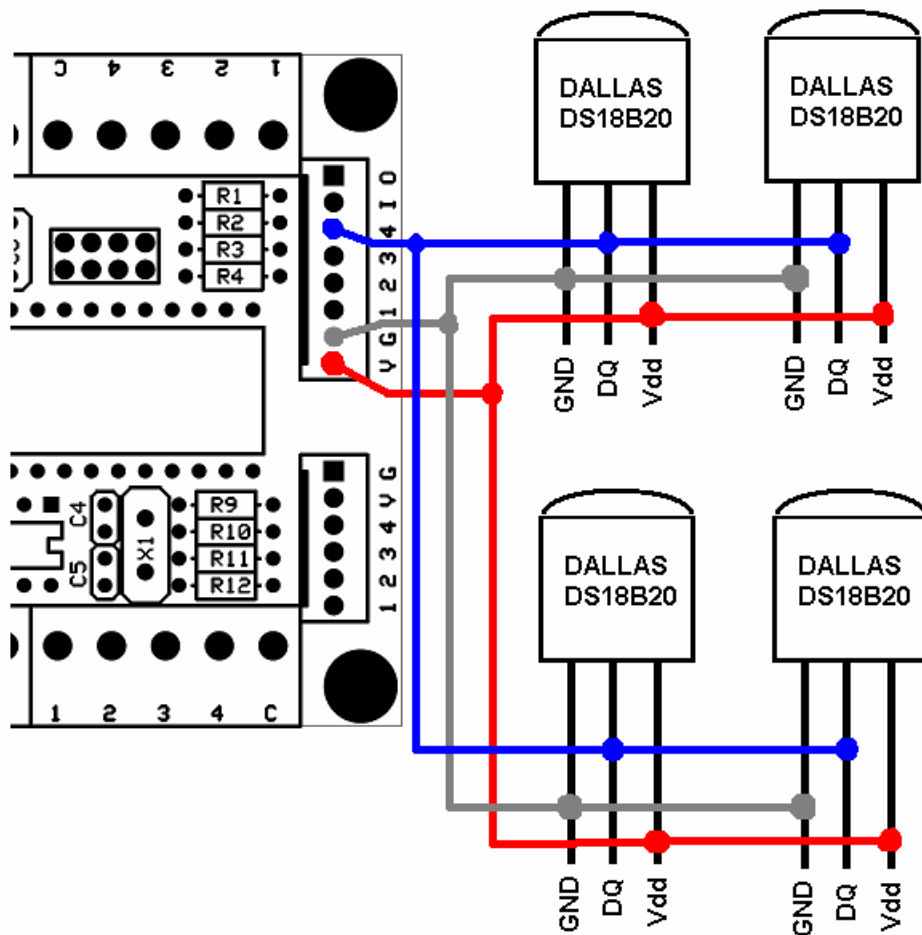

To configure RoboMicro to use the DS18B20 Digital Temperature Sensor – see the command set.